

# STI Enviro Stopper®



STI13110/FR



## KEY FEATURES

### General Information

- Protective cover is ideal for extending the life and reliability of devices exposed to harsh environments.
- Three year guarantee against breakage of polycarbonate in normal use (one year on electromechanical and electronic components).

### Design

- Cover, back box and sealed mounting plate achieves IP66 (back box) and IP56 (cover) rating.

### Construction

- Tough polycarbonate housing can withstand the severest of knocks.

### Installation

- Ideal for use in wet or wash down areas, overall rating of IP56/IP66 for the back box.
- Can accommodate a standard European call point or switch.
- Typical working properties of polycarbonate are -40° to 121°C (-40° to 250°F).

### Electronics

- Available with or without a 95 dB integral sounder, powered by a 9V PP3 battery (included).

### Options

- One breakseal is supplied with each model. Additional breakseals are available for added security.
- Available in a range of colours.
- Custom labelling available.

## PRODUCT OVERVIEW

A protective cover that is ideal for extending the life and reliability of devices exposed to harsh environments. It offers protection to manual call points and switches against dust and water ingress both outside and inside, as well as preventing tampering, vandalism and damage from accidental or malicious operation.

## HOW IT WORKS

Easy to install, the Enviro Stopper consists of a clear, tamperproof, tough polycarbonate cover and back box that can accommodate a standard European call point or switch. When the cover is closed, the unit is sealed and achieves a rating of IP66/56, preventing dust, grime and water getting to the device.

# STI Enviro Stopper®

## Dimensions and Technical Information

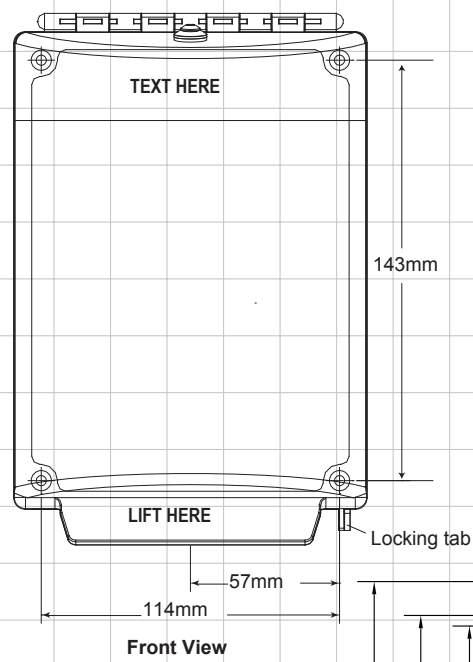

Front View

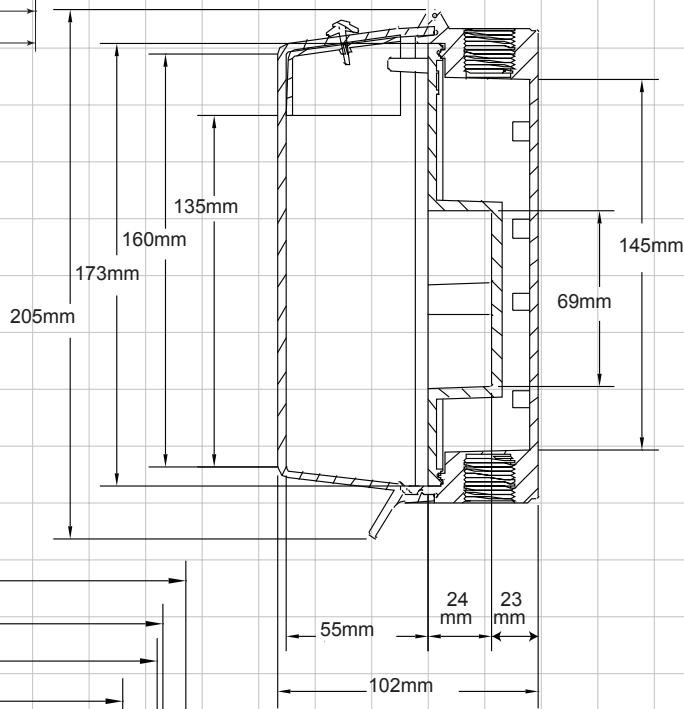

Side View

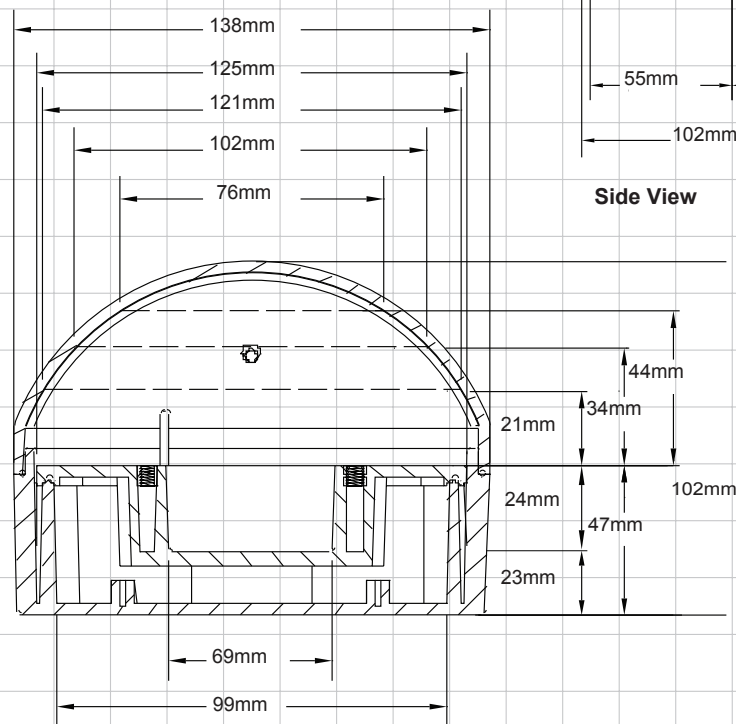

Top View

## APPROVALS

- ADA Compliant
- Cover option '3' only has been tested and approved or listed by:
- UL/CUL Listed No. S2466

**Back box, open mounting plate** - IP Rating, 56

**Back box, sealed mounting plate** - IP Rating, 66

## MODELS AVAILABLE

**STI-13610FR** Enviro Stopper, (EU enclosed plate & frosted back box) without integral sounder, with fire label.

**STI-13620FR** Enviro Stopper, (EU enclosed plate & frosted back box) with integral sounder, with fire label.

## Accessories:

**STI/BS** Break Seals (Quantity. 10)

**KIT-319** Wiring harness for remote power

**KIT-EA135** Servicing pin

**CKS001** Replacement Sounder Unit

## Options:

**COLOURS** Black, blue, green, red, white or yellow

**AVAILABLE** (to specify colour refer to Build Your Own Model)

## NB:

The Enviro Stopper is supplied in red with operating instructions:

'IN CASE OF FIRE - LIFT COVER BREAK GLASS'.

Alternative and custom markings available.

